

Tile Roof Hook Universal Mount

Installation Manual



Unirac Installation Manual



Unirac welcomes input concerning the accuracy and user-friendliness of this publication. Please write to publications@unirac.com.

Pub 090727-1ii
June 2009

© 2009 by Unirac, Inc.
All rights reserved.

Step 1: Attach roof hooks to the rafters

- Remove or slide up the roof tile
- Position the roof hook above the roof rafter (for high roof rafters, shim if necessary)
- Place Tile Hook in the middle of the underlying interlocking tile's valley.
- Drill 3/16 inch pilot holes through the underlayment into the center of the rafters. Securely fasten each tile hook to the rafters with the two 5/16" x 3 1/2" lag screws provided. (if spacer boards are used, the provided lag bolts may need to be replaced with longer ones. For proper embedment, refer to Table 2 [page 3] for lag bolt pull out values). (Fig 2)
- Slide down or re-insert the tile



Figure 1



Figure 2

Step 2: Attach L Foot to tile roof hook (Fig 3)



Figure 3

Tile Hook Components:

- 1 tile hook
- 2 lag screws
- 2 washers
- 1 stainless steel bolt
- 1 nut

Table 1. Tile Hook Spacing Chart

	Snow Load	0	5	10	15	20	25	30	35	40
<u>Basic Wind Speed</u>										
85 mph		54"	54"	47"	40"	35"	31"	28"	26"	23"
90 mph		48"	48"	44"	38"	33"	30"	27"	25"	23"
110 mph		31"	31"	31"	31"	28"	25"	23"	21"	20"
120 mph		26"	26"	26"	26"	25"	23"	21"	20"	19"
150 mph		16"	16"	16"	16"	16"	16"	16"	16"	15"

The table above is subject to the limitations listed below. It is intended as a quick reference guide based on the most common configurations. Please refer to load tables on pages 5, 6 and 7 for design loads.

Engineering Guide Limitations

- Flush roof installations only
- Roof slope must be 0-45 degrees (0/12 - 12/12 pitch)
- Installation must have at least 4 modules grouped together
- Module dimensions must be less than 42"x65"
- Surrounding ground area must not slope more than 10 degrees
- Location must fall into Exposure Category B or C.
- Building height must be less than or equal to 30'0"

Please refer to Technical Support for more information on roof zones

- Span for Roof Zone 2 = 1/2 max span
- Span for Roof Zone 3 = 1/3 max span
- Max Cantilever = 1/3 max span

Please refer to Unirac Technical Support for installations that do not comply with the limitations above.

Table 2. Lag pull-out (withdrawal) capacities (lbs) in typical roof lumber (ASD)

	Specific Gravity	Lag screw specifications 5/16" shaft,* per inch thread depth
Douglas Fir, Larch	0.50	266
Douglas Fir, South	0.46	235
Engelmann Spruce, Lodgepole Pine (MSR 1650 f & higher)	0.46	235
Hem, Fir, Redwood (Close Grain)	0.43	212
Southern Pine	0.55	307
Spruce, Pine, Fir	0.42	205
Spruce, Pine, Fir (E of 2 million psi & higher grades of MSR & MEL)	0.50	266

Use Table 2 to select a lag bolt embedment depth to satisfy your Uplift Point Load Force (lbs), requirements.

It is the installer's responsibility to verify that the substructure and attachment method is strong enough to support the maximum point loads calculated.

Sources: American Wood Council, NDS 2005, Table 1

- Notes:
- (1) Thread must be embedded in the side grain of a rafter or other structural member integral with the building structure.
 - (2) Lag bolts must be located in the middle third of the structural member.
 - (3) These values are not valid for wet service.
 - (4) This table does not include shear capacities. If necessary, contact a local engineer to specify lag bolt size with regard to shear forces.
 - (5) Install lag bolts with head and washer flush to surface (no gap). Do not over-torque.
 - (6) Withdrawal design values for lag screw connections shall be multiplied by applicable adjustment factors if necessary. See table 10.3 in the American Wood Council NDS for Wood Construction

Tile Modifications that may be required:

How do I make modifications on tile retaining lip profiles that interfere with the tile resting flat against the tile hook (figure 4)?

Tile retaining lip removal may be needed to allow for clearance of the hook.

To do so, there are two options:

Option A (figure 5): Use a hammer to remove the lip or obstruction.

Option B (figure 6): Using a grinder, remove the lip or obstruction.



Figure 4



Figure 5



Figure 6

How do I adjust upper and lower tile profiles that do not allow the tile to rest flat above the hook?

In some cases, the upper or lower tile may need to be modified; follow these steps for either situation (for illustrative purposes, we'll show the upper tile modification)

Step 1 (figure 7)

Using rolled aluminum or sheet metal flashing, cut enough material to fit the exposed area.

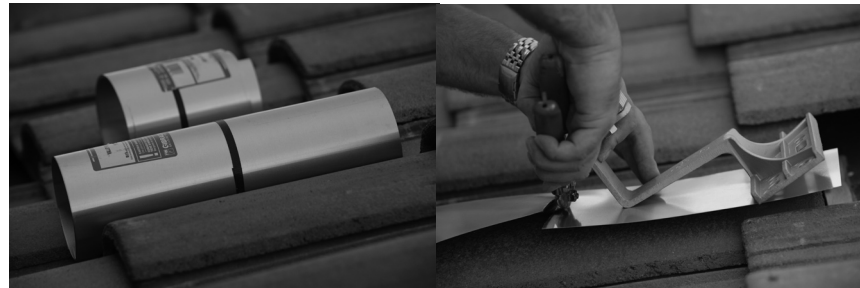

Figure 7

Step 2 (figure 8)

Modify the tile with a slot to allow for the tile hook to pass through.



Figure 8

Step 3 (figure 9)

Insert the cut flashing under the tile hook base and over the lower tile. Complete the tile hook installation as described on page 2.



Figure 9

Standard C Shaped Top Mounting Hook

Allowable Loading

Allowable Load (lbs) (1.9 Safety Factor)

Downforce	236
Uplift	191
Shear	214

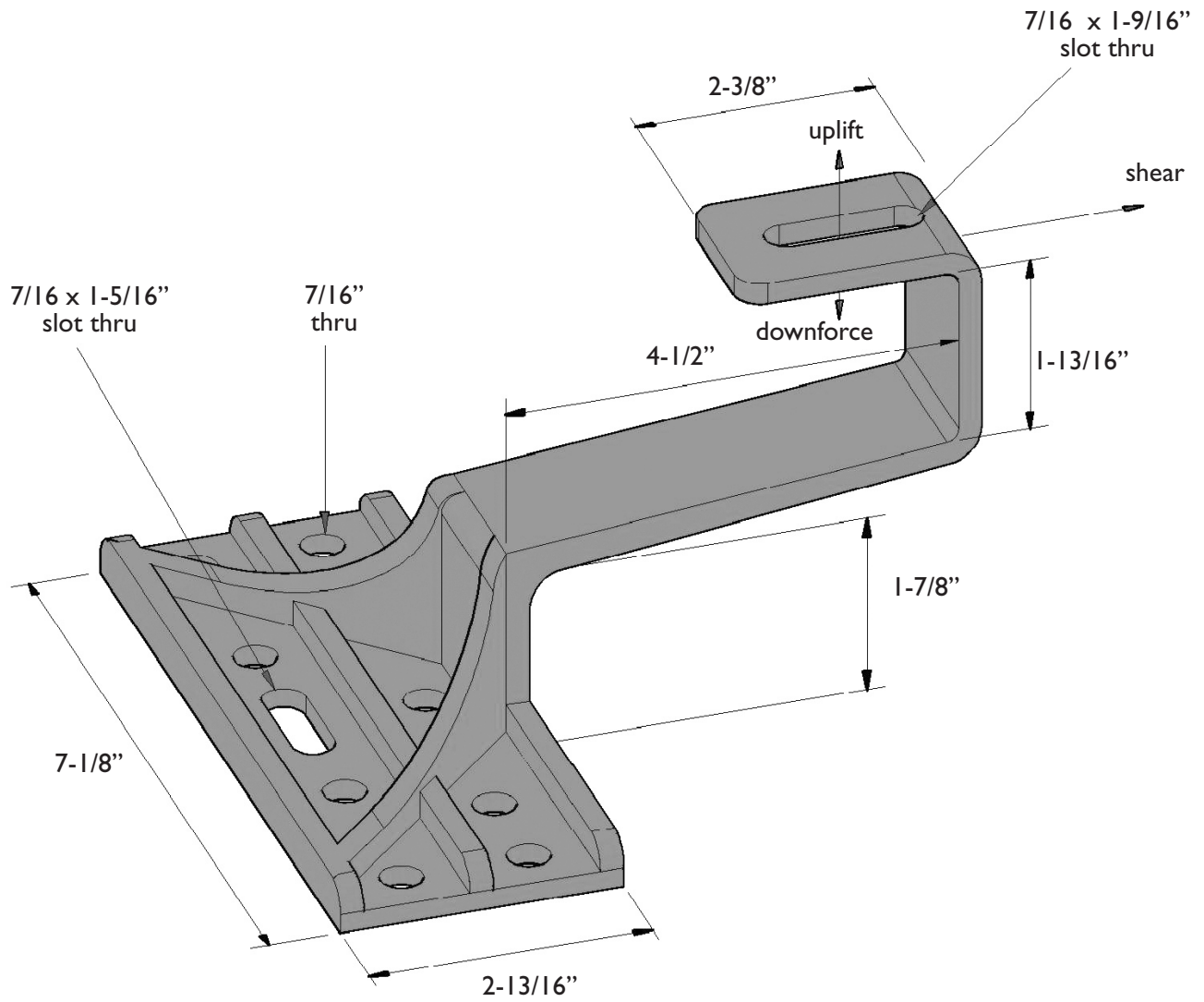

Standard S Shaped Top Mounting Hook

Allowable Loading

Allowable Load (lbs) (1.9 Safety Factor)

Downforce	303
Uplift	303
Shear	348

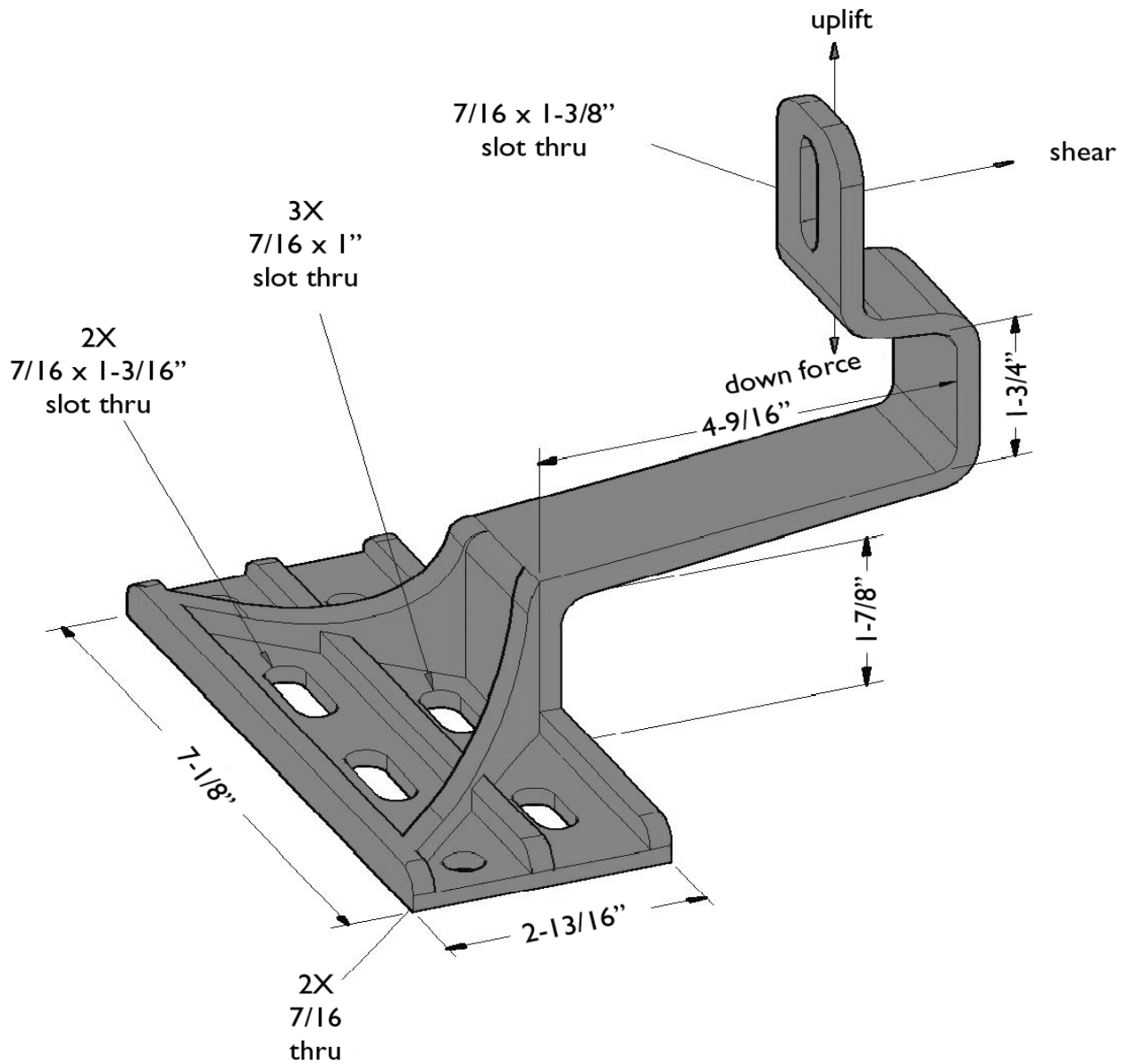

Standard S Shaped Side Mounting Hook

Allowable Loading

Allowable Load (lbs) (1.9 Safety Factor)

Downforce	337
Uplift	225
Shear	259

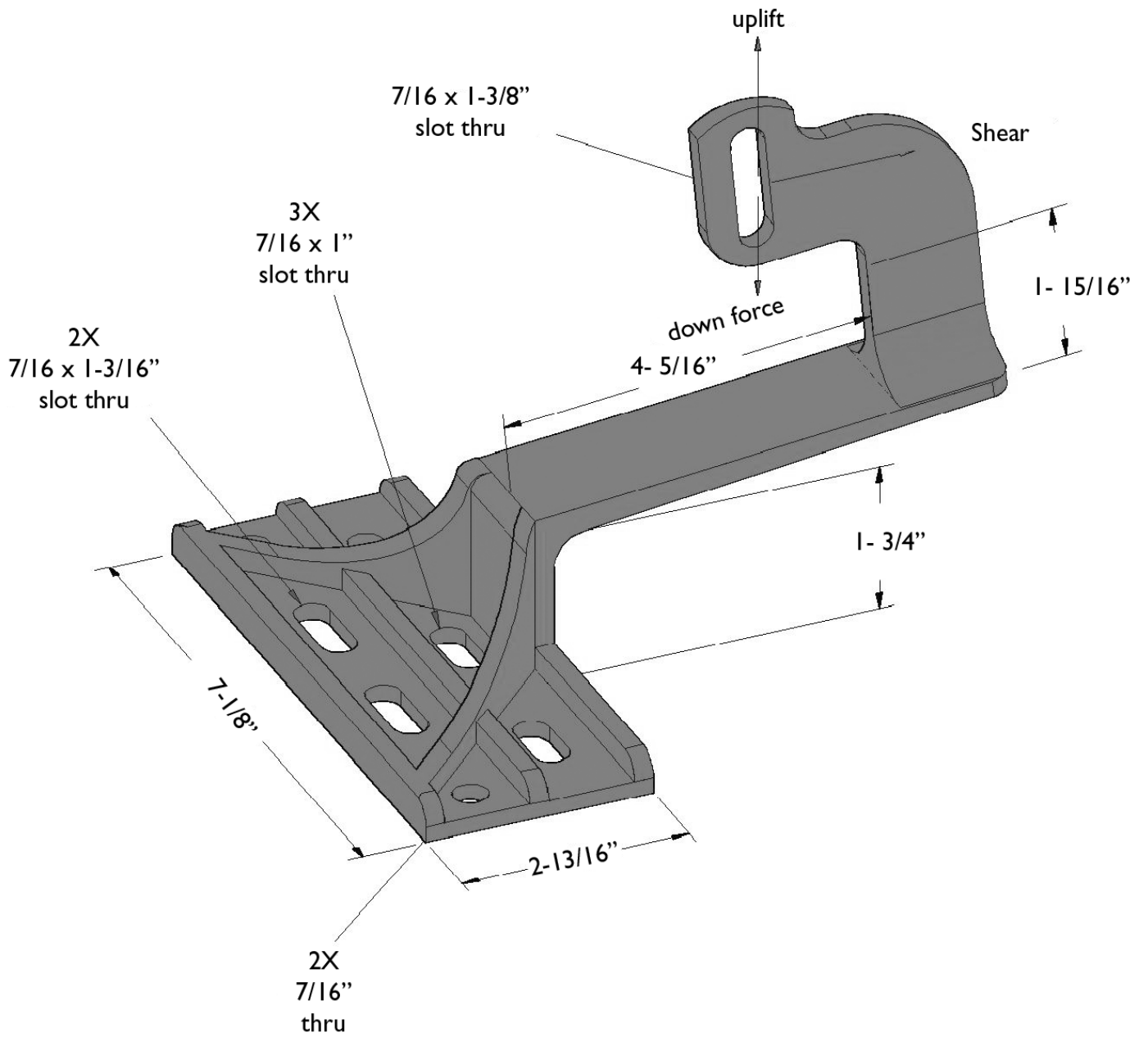

10 year limited Product Warranty, 5 year limited Finish Warranty

Unirac, Inc., warrants to the original purchaser ("Purchaser") of product(s) that it manufactures ("Product") at the original installation site that the Product shall be free from defects in material and workmanship for a period of ten (10) years, except for the anodized finish, which finish shall be free from visible peeling, or cracking or chalking under normal atmospheric conditions for a period of five (5) years, from the earlier of 1) the date the installation of the Product is completed, or 2) 30 days after the purchase of the Product by the original Purchaser ("Finish Warranty").

The Finish Warranty does not apply to any foreign residue deposited on the finish. All installations in corrosive atmospheric conditions are excluded. The Finish Warranty is VOID if the

practices specified by AAMA 609 & 610-02 – "Cleaning and Maintenance for Architecturally Finished Aluminum" (www.aamanet.org) are not followed by Purchaser. This Warranty does not cover damage to the Product that occurs during its shipment, storage, or installation.

This Warranty shall be VOID if installation of the Product is not performed in accordance with Unirac's written installation instructions, or if the Product has been modified, repaired, or reworked in a manner not previously authorized by Unirac IN WRITING, or if the Product is installed in an environment for which it was not designed. Unirac shall not be liable for consequential, contingent or incidental damages arising out of the use of the Product by Purchaser under any circumstances.

If within the specified Warranty periods the Product shall be reasonably proven to be defective, then Unirac shall repair or replace the defective Product, or any part thereof, in Unirac's sole discretion. Such repair or replacement shall completely satisfy and discharge all of Unirac's liability with respect to this limited Warranty. Under no circumstances shall Unirac be liable for special, indirect or consequential damages arising out of or related to use by Purchaser of the Product.

Manufacturers of related items, such as PV modules and flashings, may provide written warranties of their own. Unirac's limited Warranty covers only its Product, and not any related items.