



## **GROUND MOUNT INSTALLATION OVERVIEW:**

The Professional Solar PV ground mounting system is a simple, easy to install, fully engineered ground mount solution for photovoltaic solar modules. This system is designed to engineer with a minimum amount of installed footings at greatly reduced labor. The system integrates with ordinary 1-1/2" schedule #40 galvanized pipe. This ground mount solution includes virtually everything needed to install modules with vertical posts up to 5" from grade. The installer will only need pipe, concrete and basic construction skills to complete the installation. This fully engineered system utilizes Professional Solar Products' patented Slide-n-Clamp™ module clamps and support channel - the industry standard for rooftop module installations.

Installation of the ground mount system consists of the following:

- Installation 1-1/2" schedule #40 galvanized pipe (max. span = 10' O.C. using the special alloy tees—non-snow load conditions).
- Installation of vertical pipe supports into concrete footings.
- Drilling and installation of the main support channels to the specially machined "U-Bolt" assemblies.
- Installation of the solar modules using the standard Roof Trac<sup>®</sup> "Slide-n-Clamp" module mounting system.

### **Ground Trac™ TOOL LIST:**

- |                                 |                                               |
|---------------------------------|-----------------------------------------------|
| 1. Post hole digger             | 9. 7/16" deep socket & ratchet                |
| 2. Wheelbarrow / shovel         | 10. Phillips head driver (for drywall screws) |
| 3. String Line                  | 11. 1/2" wrench                               |
| 4. Line level or builders level | 12. 3/16" hex wrench                          |
| 5. Drill                        | 13. Framing square                            |
| 6. 1/2" Uni-Bit                 | 14. Pipe cutter or reciprocating saw          |
| 7. Tape Measure                 | 15. Pipe wrenches (two required)              |
| 8. Sharpie™ marking pen         | 16. Mallet or large hammer                    |

**STEP #1**

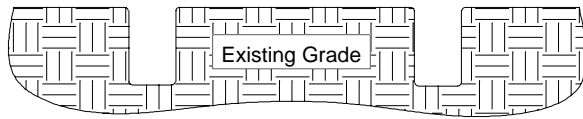

SIDE VIEW

Excavate footings as per detail or engineered plan

**STEP #2**

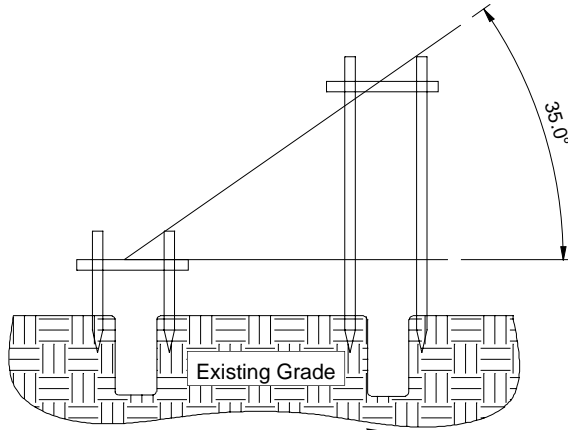

SIDE VIEW

Determine the proper angle for the module array and install grade stakes as illustrated (left), do not exceed 5 ft. of vertical post length from grade.

Installing the supports braces will hold the pipe at the proper fixed angle until the footings are poured. We recommend the use of drywall screws to hold the horizontal brace in place until concrete sets. Install the end braces and then set up a string line to insure alignment. Place supports at a distance that will allow the pipe beam to be supported without sagging.

Distance of base depends upon the angle of support channel.

**STEP #3**

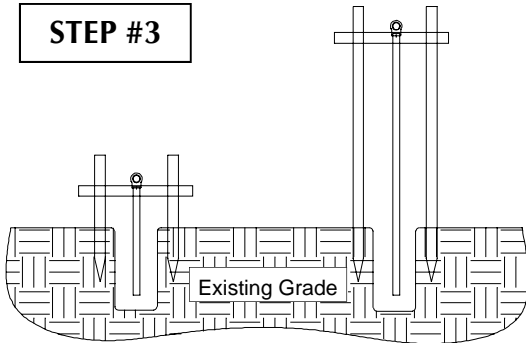

SIDE VIEW

Illustrated (left) pipe support beams and vertical post supports can now be assembled and rest on the support bracing. Using two pipe wrenches and 3/16" hex wrench, the pipe and support legs can be assembled and are ready for the Roof Trac<sup>™</sup> module channel to be installed.

*Special Note: Use only schedule #40 galvanized pipe, fence tube is not recommended*

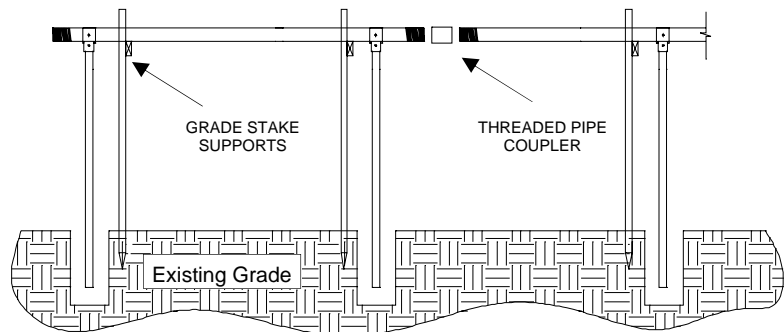

Rear view of pipe support beam bracing and

**STEP #4**

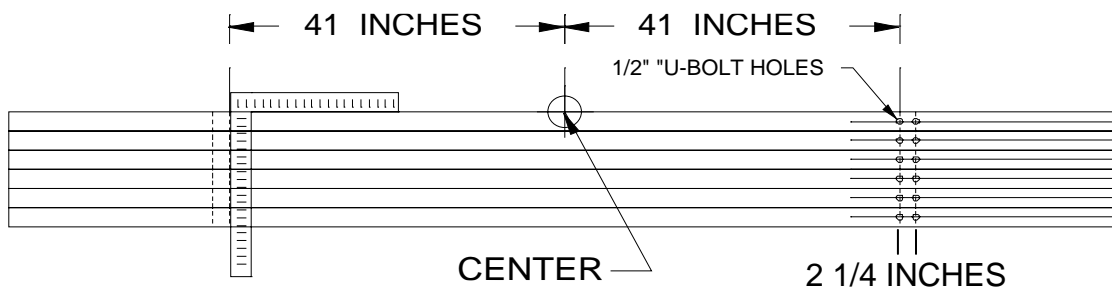

Drilling of the support channels: Align the support rails with the bottom side up on a flat surface. Using a framing square as illustrated, measure from the center of the channel 41" outward and mark a line on the channel. Mark another line exactly 2" outward from center from the first line. Now drill the "U-Bolt" holes in alignment with the marked line and the specially extruded "V" groove on the channel. We recommend the use of a 1/2" "Uni-Bit®" bit for this. You will now have perfectly aligned holes ready for installation on the support pipe beams.

**STEP #5**

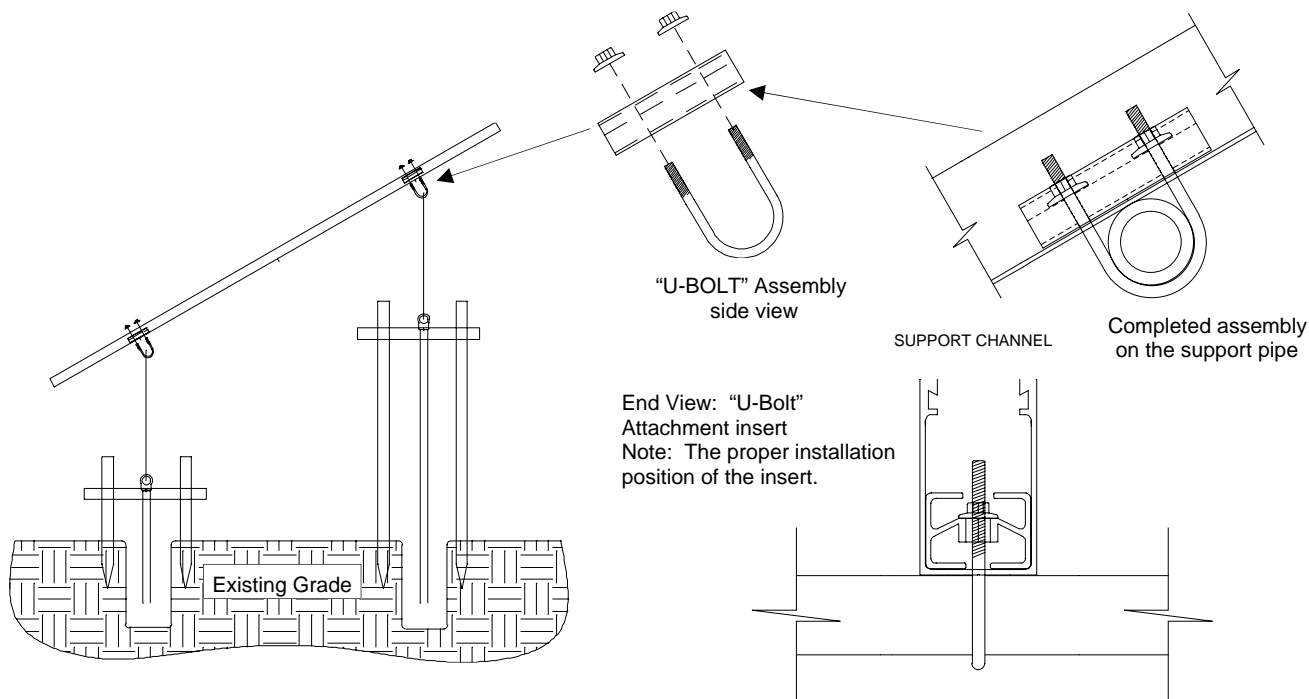

**STEP #6**

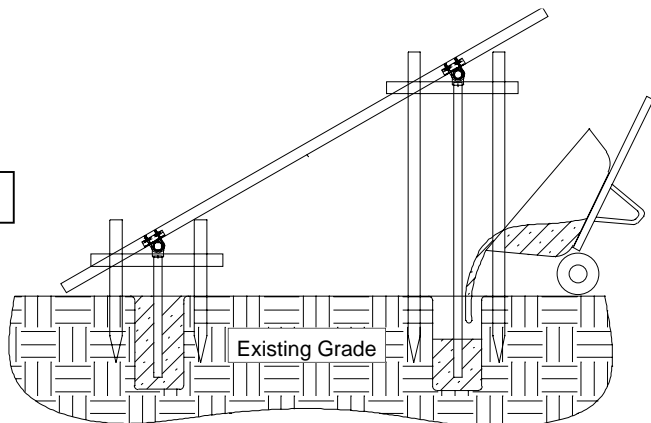

Align the end of the channel using a string line. Tighten all the "U-Bolt" assemblies and re-check alignment the vertical pipe supports. You are now ready to pour concrete into the footings. Tap the concrete to ensure contact with the vertical pipe support. Remove the support bracing after the concrete has set. You are now ready to install your modules.

**CAUTION:** Extruded edges of the aluminum can be sharp. It is highly recommended the installer buff the edges after installation to prevent injury.

## ESTIMATING AMOUNT OF PIPE AND CONCRETE:

- 1 To estimate the amount of galvanized pipe needed for the rack, count the total number of panelized modules in a bank. Determine the width of the module, for example (58" x number of grouped panels (6) = 348" x 2 = 696" / 12 = 58') Since galvanized pipe comes in 21' lengths, you will need 6 lengths for the upper and lower beams to avoid cutting and threading the pipe.
- 2 To determine the number of posts (the maximum allowable span is 10') take the total length of one of the beams less 4' (2' allowable overhang on each end) and divide this by 10 (see figure 1). This will give you the amount of posts required to support one of the beams, doubling this will give you the number of posts and TEE's required.
- 3 Estimating the amount of pipe required for the posts can be estimated by adding 40" (footing) plus the distance from the top of the footing -grade to the beam (figure 2). Add the total length of pipe for the beams and the footings and divide by 21 (standard length of pipe). This will give you the amount of pipe lengths needed required for the installation.
- 4 Concrete for the footings = approximately 2.6 cubic feet per post.

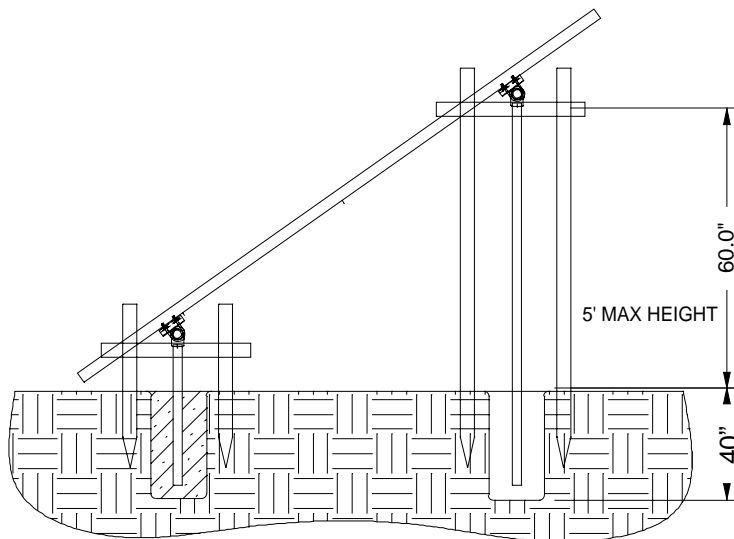
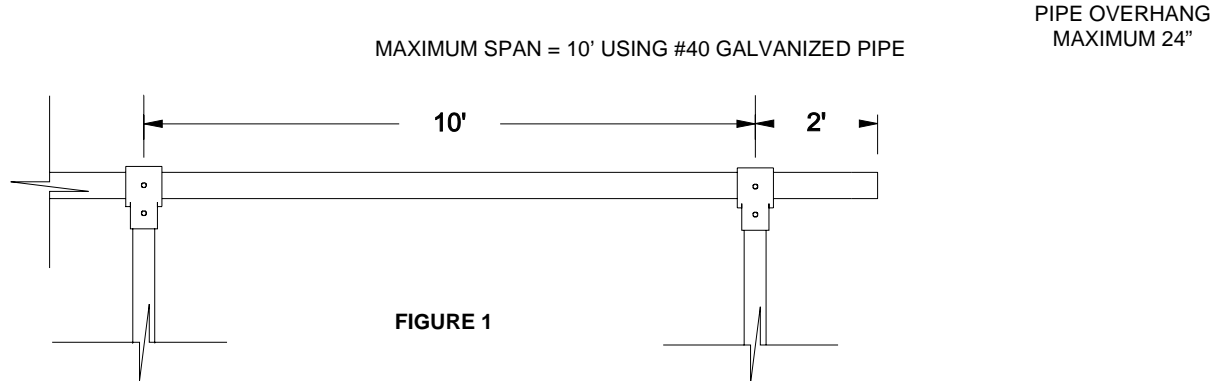

### Recommended Safety Installation Procedures:

- 1 Installer must insure that all sharp extrusion edges should be buffed and smooth to avoid injuries from sharp extrusion edges.
- 2 All pipe ends should be capped using a 1-1/2" PVC slip caps.
- 3 When ground mounting racking is installed in common areas, it must be properly lit to avoid injury from people walking into it.
- 4 If installed on steep slopes or unstable soil, footings should be sufficiently sized or engineered for these conditions.
- 5 Observe all electrical safety procedures and ensure proper grounding as established by both the module and inverter manufacturers.
- 6 Insure all support TEE set screws are properly tightened and always use schedule #40 galvanized pipe (fence post is not recommended). Torque rating for Hollelander tee fitting = 17 ft. lbs.