

PowerGate™ inverters offer market-leading reliability, efficiency and ease-of-use for large-scale grid-connected photovoltaic systems. A single-enclosure solution, the utility-grade PowerGate™ incorporates a high-efficiency transformer and both AC and DC switchgear that disconnect the inverter at night, minimizing tare losses. A highly efficient MPPT tracking algorithm and intelligent wake-up routine further maximize net energy harvest. The PowerGate™ is certified to UL-1741 and is available with a variety of local and remote data monitoring options.



Utility-Grade Design

20-year design life • Reverse convection top-air entry
• Sloped roof • 25-year film-type capacitors • 5-year standard warranty • Extended warranties available

Easy Installation and Use

Single enclosure minimizes field wiring • Integrated high-efficiency transformer • Optional integrated sub-array combiner • Internal AC and DC switchgear • Top and bottom cable entry • Top-lifting eye-bolts and forklift base

Superior Energy Harvesting

Industry leading efficiency • Automatic night disconnect minimizes transformer losses • High-speed MPPT • Soft charge network minimizes in-rush current and nuisance trips • Wide input voltage range

Remote and Local Data Monitoring

4-line alphanumeric LCD display • Optional *PV View* web enabled data monitoring • Optional *PV Zone* sub-array performance monitoring • RS485 Modbus

Safety

Certified to UL 1741 • Integrated DC contactor for array isolation • Surge withstand testing to ANSI 62.41 and IEEE1547-2003

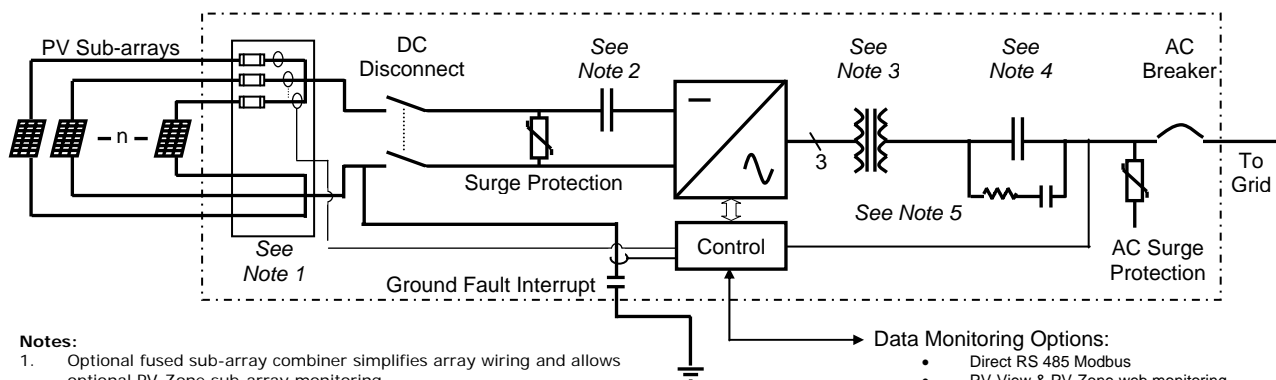

Notes:

1. Optional fused sub-array combiner simplifies array wiring and allows optional PV-Zone sub-array monitoring
2. Contactor provides backfeed protection and automatic array fault isolation
3. Integrated high-efficiency transformer
4. Integrated AC contactor opens at night and minimizes standby losses
5. Pre-charge circuit minimizes in-rush current and nuisance trips

Data Monitoring Options:

- Direct RS 485 Modbus
- PV-View & PV-Zone web monitoring
- Revenue grade kWhr metering
- Meteorological
- Consult SatCon for details

Specifications – Model Specific

Power (kWac)	75			100		
Model #	AE-75-60-PV			AE-100-60-PV		
Voltage Suffix	D	F	A	D	F	A
AC Output Voltage (L-L Vac)	208	240	480	208	240	480
Nom Current/Phase (Amps)	208	181	91	278	241	121
Max Fault Current/Phase (Amps)	260	230	115	350	290	150
CEC Efficiency (%)	95	NA	95.5	94.5	95	94.5
Nominal DC Current (Amps)	240			319		
Optional PV Sub- Array Combiner (# of fused strings)	6 x 100 Amps			6 x 100 Amps		
Max. Weight (lbs) [kg]	2600 [1180]			3250 [1475]		
Max Heat Dissipation (kBTU/hour)	10.5			13.6		

Specifications – All Models

Nominal MPP DC range (Vdc)	330-600
Max MPPT Range (Vdc)	295-600 (Note)
Max Voc (Vdc)	600
Nom. Frequency Range (Hz)	59.5 - 60.5
AC Voltage Range Setpoints (%)	+/- 10
Power Factor	1
Harmonic Distortion (% THD)	<3
Peak Efficiency (%)	95-97
Cooling	Fan Forced
Noise level (dBA)	<65
Ambient Temp. range (degC)	-20 to 50
Max amb. temp. at Pnom (degC)	50
Enclosure rating	NEMA 3R
Enclosure Construction	11 gauge Powder Coated Steel - Seismic Zone 4

Relative humidity(%)	95
Altitude (ft) [m]	6000 [1830]
Display	LCD 4 Line x 20
Computer interface / type	RS232, RS485
Communication Protocol	Modbus
Standard Warranty	5 Year
Certification	UL 1741
Compliances	IEEE 929, 1547, 519, ANSI 62.41

Optional Features

PV View® Remote Monitoring
PV Zone® Sub-Array Monitoring
Environmental monitoring
External revenue grade meter

Note: To achieve 295 volts “Low tap” must be specified at time of order. Unit will derate if grid voltage is < nominal.

Enclosure Layout and Dimensions

HxWxD (in) [mm]	75.63x53x30 [1921x1350x762]
-----------------	--------------------------------

Top Gland Plate

A (in) [mm]	20x8 [508x203]
B (in) [mm]	15 [381]
C (in) [mm]	8 [203]

Bottom Gland Plate

A (in) [mm]	20x6 [508x152]
B (in) [mm]	15 [381]
C (in) [mm]	4 [102]

