



12V 300Ah LiFePO4 Monobloc Battery

Performance

Voltage	12V
Capacity	300Ah
Efficiency	99%
Self-Discharge Maximum	3% per month
Cycles	6,000 cycles at 80% DoD
Built-in BMS	Internal
Resistance	< 30 mΩ
Usable DoD	100%
Parallel and Series Connection	16 in Parallel or 4 Parallel - 4 Series

Mechanical

Dimensions	19.69" L x 10.43" W x 9.2" H
Weight	81.8 Lbs.
Terminal Type	Threaded Insert
Terminal Hole	M8 Bolt
Terminal Torque	8-12Nm
Case Material	ABS+PC Fire Rated
Cell Type - Electrolyte	LiFePO4
IP Rating	IP67

Certifications

Certifications	UN38.3, UL 1973 Recognized Component, IEC62619, CE
Cell	UN38.3, UL9540A, UL1642
Shipping Class	UN38.3, UN3480, Class 9

Charging

Recommended Charge Current	150A
Max Charge Current	300A
Absorption Voltage	14.2 - 14.6V
Float Voltage	13.6 - 13.8V
Absorption Time	60 minutes per 100Ah
BMS Cell Balancing Voltage Range	13.4 - 14.6V
Temperature Compensation	Not Required

Discharging

Recommended Discharge Current	150A
Max Discharge	300A
Peak/Surge Current Limit	1000A for 5S
Recommended LVD	11 - 11.6V
BMS Discharge Voltage Cut-Off	10.6 - 11V
Reconnect Voltage	11.8 - 12.2V
Short Circuit Protection	Yes
Short Circuit Protection	1200A / 500us

Temperature

Operational Temperature	-4° to 140°F (-20 to 60°C)
Discharge Temperature	-4° to 140°F (-20 to 60°C)
Charge Temperature	32° to 140°F (0° to 60°C)
Storage Temperature	59° to 95°F (15° to 35°C)
BMS High Temperature Cut-Off	149°F (65°C)
BMS Reconnect (Charge)	113°F (45°C)
BMS Reconnect (Discharge)	122°F (50°C)

Product Outline*

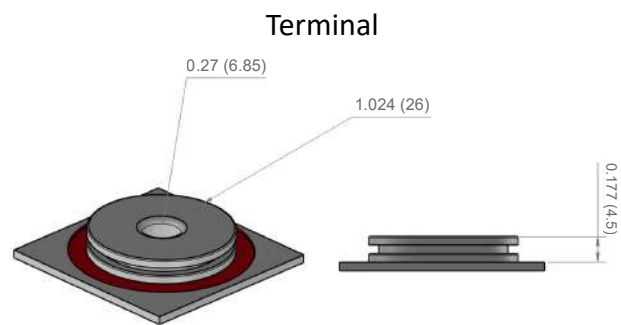
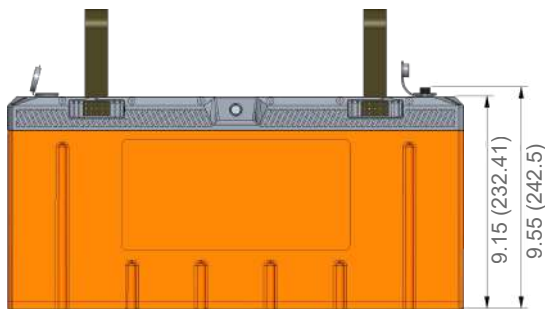
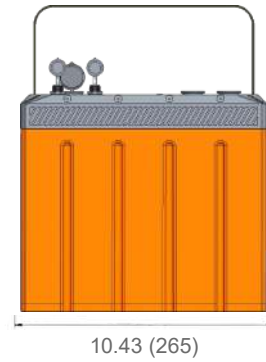
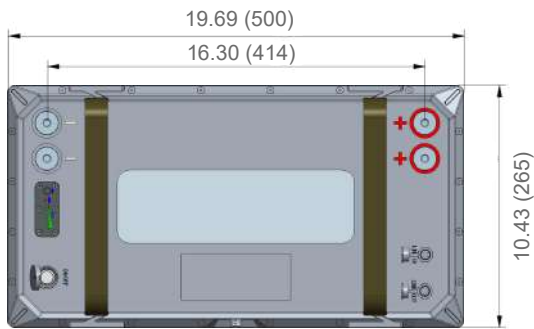

*Inch (mm)

Cycle Life vs DoD @ 25°C

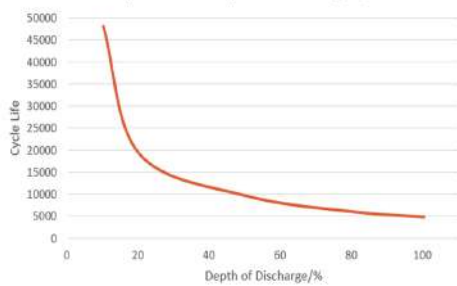

0.5C @ 80% DoD Cycle Life

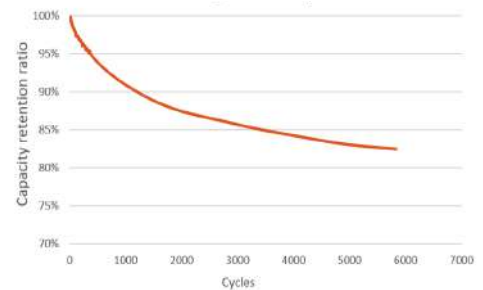

1C Charge Characteristics @ 25°C

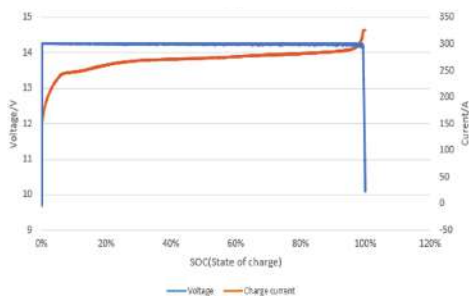

Discharge Curve at Different Rates @ 25°C

